

DEPARTMENT OF THE ARMY TECHNICAL BULLETIN

INSTALLATION AND REMOVAL INSTRUCTIONS FOR THE TRIMBLE
TRIMPACK GLOBAL POSITIONING SYSTEM (GPS) SPECIAL
MISSION KITS ON OH-58C (FLAT GLASS) HELICOPTERS

Headquarters, Department of the Army, Washington, D. C.
15 June 1995

DISTRIBUTION STATEMENT A. Approved for public release; Distribution is unlimited.

NOTE

THIS PUBLICATION IS EFFECTIVE INDEFINITELY UNLESS SOONER RE-
SCINDED OR SUPERSEDED.

1. **PRIORITY.** This technical bulletin is classified **ROUTINE**.
2. **PURPOSE.** This Technical Bulletin to only be applied if dictated by mission requirements. It provides instructions for the temporary installation of provisions for a GPS Trimpack receiver on the upper center surface of the main instrument panel glareshield in the cockpit and a remote antenna on the upper wire strike cutter. When the GPS is installed, it will provide the copilot/observer with information on aircraft position for navigation.
3. **APPLICABLE END ITEM(S) OR SYSTEM(S).**

System(s) affected.

| NOMENCLATURE | NSN | PART NO. | CAGE | TYPE/ MODEL | SERIAL NO. RANGE |
|----------------------------|------------------|----------|-------|----------------|--|
| Helicopter, Observation | 1520-01-020-4261 | OH-58C | 97499 | OH-58C | As dictated by mission requirements. See note below. |

NOTE

Each installation of the Trimble Trlmpack GPS requires prior approval of unit's MACOM. Operation of GPS shall be in accordance with Interim Statement of Airworthiness Qualification (ISAQ) dated 6 March 1995 or later revision.

4. KIT(S)/PART(S) AND THEIR DISPOSITION.

NOTE

Before starting application do a complete Inventory of both kits.

a. Kit(s)/part(s) needed for this application:

| Nomenclature | NSN | CAGE | Part Number | Security | Weight |
|-------------------------------|------------------|-------|-------------------------|----------|----------|
| Kit A | | 20309 | 90209246-502 | Normal | 7.0 lbs. |
| Kit B | | | | Normal | |
| Antenna, GPS | | 65457 | 12038-00 or 16248-40 | | 0.3 lbs. |
| Receiver, Trimble Trimpack | | 65457 | 16768-10 or 16768-20 | | 4.2 lbs. |
| ANVIS Modification Kit | 5895-01-340-5502 | 80063 | A3154590-2 | | 1.0 lb |

b. Contents of Kit A:

| NOMENCLATURE | NSN | CAGE | PART NUMBER | QTY |
|-------------------------|------------------|-------|--------------|-----|
| Cable, Power. | * | 20309 | 90209183-504 | 1 |
| Cable, Antenna | * | 20309 | 90209182-506 | 1 |
| Cable, Antenna | * | 20309 | 90209182-507 | 1 |
| Circuit Breaker, 1A | 5925-00-929-7716 | 96906 | MS26574-1 | 1 |
| Clamp, Wire | 5340-00-598-0146 | 96906 | MS21919WDG-3 | 1 |
| Mount, Antenna LS | * | 20309 | 90209223-1 | 1 |
| Mount, Antenna RS | * | 20309 | 90209223-2 | 1 |
| Template, Antenna | * | 20309 | 90209223-3 | 1 |
| Template, Connector | * | 20309 | 90209223-4 | 1 |
| Panel, Ant. Blank off | * | 20309 | 90209175-501 | 1 |
| Placard | * | 20309 | 90209223-5 | 1 |
| Sleeve Assy, Trmpk | * | 20309 | 90209178-501 | 1 |
| Support, Upper, LS | * | 20309 | 92276482-1 | 1 |
| Support, Upper, RS | * | 20309 | 92276482-2 | 1 |
| Plate, Adapter | * | 20309 | 92276483-1 | 1 |
| Support, Lower | * | 20309 | 92276484-1 | 1 |
| Jumper Assy | * | 20309 | 90209223-6 | 1 |
| Terminal Lug #6 | 5940-00-204-8966 | 96906 | MS25036-102 | 1 |
| Terminal Lug #10 | 5940-00-143-4771 | 96906 | MS25036-103 | 1 |
| Strap, Tiedown (Tywrap) | 5975-00-984-6582 | 96906 | MS3367-1-0 | 20 |
| Rivet, Blind | 5320-01-138-4239 | 81349 | M7885/2-4-03 | 16 |
| Bolt, Machine | 5306-00-151-0785 | 88044 | AN3-7A | 3 |
| Screw, . 164-32 | 5305-00-984-6195 | 96906 | MS35206-247 | 7 |
| Screw, . 190-32 | 5305-00-989-6265 | 96906 | MS35207-262 | 6 |
| Washer, Flat #8 | 5310-00-558-6207 | 88044 | AN960C8L | 4 |
| Washer, Flat #10 | 5310-00-167-0812 | 88044 | AN960C10L | 18 |
| Nut, Self Lock 1032 | 5310-00-807-1474 | 96906 | MS21042L3 | 9 |

* NSN to be assigned

b. Contents of Kit B (Obtain as individual components):

| NOMENCLATURE | NSN | CAGE | PART NUMBER | QTY |
|----------------------------|------------------|-------|----------------------|-----|
| Antenna, GPS | 5895-01-340-5502 | 65457 | 12038-00 or 16248-40 | 1 |
| Receiver, Trimble Trimpack | | 65457 | 16768-10 or 16768-20 | 1 |
| ANVIS Modification Kit | | 80063 | A3154590-2 | 1 |

NOTE

Refer to the small light weight Global Positioning System Receiver (SLGR) support plan, airborne and ground application, for return or repair instructions for failed Trimble Trimpack equipment. Prior to fielding the Trimpack, instructions on logistics support will be provided to gaining unit commanders and/or Logistics Assistance Representatives.

5. APPLICATION.

a. Category of Maintenance: Aircraft downtime will be charged to AVUM Maintenance.

- (1) AVIM for Kit A installation.
- (2) AVUM for Kit A removal and Kit B installation/removal.

b. Requirements: Work force and man-hour requirements for Kit A application of this technical bulletin(TB) to single unit, end item, or system is as follows:

REQUIREMENTS

| WORK FORCE/SKILLS | MAN-HOURS |
|--------------------------|-----------|
| Aircraft Electrician (1) | 2 |
| Sheet Metal Repairer (1) | 2 |

Total man-hours required for single application of this TB is 4 hours.

c. TB/MWO(s) to be applied prior to or concurrently this TB. Not Applicable.

6. PUBLICATIONS WHICH REQUIRE CHANGE AS A RESULT OF THIS TECHNICAL BULLETIN. Not Applicable.

NOTE

Operator and Maintenance Guide will be provided with GPS Trimpack Receiver.

7. SUPPLY/PARTS AND THEIR DISPOSITION.

Bulk and expendable material.

| NOMENCLATURE | NSN | CAGE | PART NUMBER | QTY |
|--|------------------|-------|----------------------------|-----|
| Chemical Conversion Coating (Alodine 600) | 8030-01-018-2838 | 80244 | MIL-C-81706, CI 3, FM 2 | KT |
| Primer Coating Kit, Epoxy | 8010-01-314-6076 | 81349 | M23377-21-0012 | KT |
| Sealant | 8030-00-723-2746 | 81205 | MIL-S-8802 | KT |
| Tape, Pressure Sensitive | 7510-00-283-0612 | 99742 | PPP-T-42 | YD |
| Coating, Aliphatic Polyurethane | 8010-01-316-2221 | 81349 | MIL-C-46168 | KT |

8. SPECIAL TOOLS; TOOL KITS; JIGS; TEST, MEASUREMENT AND DIAGNOSTIC EQUIPMENT (TMDE); AND FIXTURES REQUIRED.

| NOMENCLATURE | NSN | CAGE | PART NUMBER | QTY |
|--------------|------------------|-------|------------------------------|-----|
| Multimeter | 6625-00-999-7465 | 80058 | AN/USM-223(or equivalent) | 1 |

9. INSTALLATION PROCEDURES FOR KIT A. The following procedures contain instructions for installing/ removing the GPS Trimpack and provisions on OH-58C helicopters.

CAUTION

- To prevent damage or loss, items removed to gain access to work areas shall be tagged for identification and protected from damage before reinstallation. Retain all attaching hardware and identification markers unless otherwise directed.
- Ensure that a foreign object damage (FOD) prevention program is implemented during application of this TB in accordance with AR 385-95, Chapter 4.

NOTE

- Refer to TM 55-1520-22823 and TM 11-1520-228-23 for detailed removal and installation instructions not contained herein and TM 55-1520-228-23P for detailed parts location.
- Refer to TM 55-1500-323-24 for detailed instructions concerning aircraft electrical and electronic wiring Installation practices.
- Refer to TM 1-1500-204-23 for detailed instructions concerning aircraft sheet metal practices.
- Refer to TM 55-1500-345-23 for painting and marking practices.
- If Trimpack Sleeve Assembly (P/N 90209-501) has not been modified, modify per Figure 8.

a. Aircraft preparation.

- (1) Prepare aircraft for safe ground maintenance.
- (2) Lower overhead console circuit breaker panel for access to power distribution wiring.

(3) Remove upper cabin sound proofing blanket as required to gain access to wire bundles and GPS antenna cable routing.

b. Prepare upper wire strike cutter for installation of Trimpack remote antenna mounts (P/N 90209223-1 and P/N 90209223-2) (Figure 1).

NOTE

If hole exists in upper wire strike cutter approximately 4.94 inches down from top aft corner of cutter go to step (1) below. If no hole exists go to step (2) below.

(1) Align center hole in template (P/N 90209223-3) with hole in cutter.

(a) Secure template (P/N 90209223-3) to cutter with bolt (P/N AN3-7A), washer (P/N AN960C10L) and nut (P/N MS21042-L3).

(b) Using template (P/N 90209223-3) as a guide, drill two pilot holes through cutter.

(c) Remove bolt (P/N AN3-7A), washer (P/N AN960C10L) and nut (PIN MS21042-L3) from template and cutter. Remove template.

(d) Ream out two holes in cutter to 0.204 inches.

(e) Clean and deburr holes.

(f) Go to step (3) below.

(2) Align template (P/N 90209223-3) with top aft edge of cutter.

(a) Using template (P/N 90209223-3) as a guide, drill three pilot holes through cutter.

(b) Remove template.

(c) Ream out three holes in cutter to 0.204 inches.

(d) Clean and deburr holes.

WARNING

Chemical conversion coating is flammable and toxic. It can irritate skin and cause burns. Use only in well-ventilated area, away from heat and open flame. Wear gloves, goggles, apron, and respirator. In case of contact, immediately flush skin or eyes with water for at least 15 minutes. Get medical attention for eyes.

CAUTION

Chemical conversion coating is highly corrosive. Do not allow chemical conversion coating or rinse water to run into cracks, crevices, seams, or joints.

(3) Surface treat antenna mount holes with Chemical Conversion Coating (MIL-C-81706).

WARNING

Epoxy primer coating and Aliphatic Polyurethane Coating are flammable and toxic. They can irritate skin and cause burns. Use only in well ventilated area away from heat and open flame. Wear approved respirator, apron solvent resistant rubber gloves and chemical splash goggles. Thoroughly wash skin area with soap and water. Flush eyes with water for 15 minutes. Get immediate medical attention for eyes.

- (4) Prime antenna mount holes with epoxy primer coating (MIL-P-23377).
- (5) Install antenna mounts (P/N 90209223-1 and P/N 90209223-2) on upper wire strike cover (Figure 1).
 - (a) Align mounts (P/N 902092231 and P/N 90209223-2) with previously drilled holes (Figure 1).
 - (b) Secure mounts to cutter with three bolts (P/N AN3-7A), six washers (P/N AN960C10L) and three nuts (P/N MS21042L3).
- c. Trimpack Receiver Mount installation Instructions (Figure 2).
 - (1) Remove two existing screws from upper surface of instrument panel glareshield. Retain screws.
 - (2) To locate mounting position and mount the upper supports (P/N 92276482-1 and P/N 92276482-2) to windshield center post:
 - (a) Measure down approximately thirteen inches from corner of windshield.
 - (b) Remove rivet from each side of center post (TM 1-1500-204-23).
 - (c) Temporarily attach adapter plate (P/N 92276484-1) to upper supports (P/N 92276482-1 and P/N 92276482-2).
 - (d) Place upper supports (P/N 92276482-1 and P/N 92276482-2) against center post and identify remaining rivets to be removed.
 - (e) Remove rivets identified (TM 1-1500-204-23).
 - (f) Transfer hole locations to upper supports (P/N 92276482-1 and P/N 92276482-2).
 - (g) Drill seven 0.128 holes in upper supports (P/N 92276482-1 and P/N 92276482-2) (ensure sufficient edge distance before drilling).
 - (h) Clean and deburr holes.

WARNING

Chemical conversion coating is flammable and toxic. It can irritate skin and cause burns. Use only in well-ventilated area, away from heat and open flame. Wear gloves, goggles, apron, and respirator. In case of contact, immediately flush skin or eyes with water for at least 15 minutes. Get medical attention for eyes.

CAUTION

Chemical conversion coating is highly corrosive. Do not allow chemical conversion coating or rinse water to run into cracks, crevices, seams, or joints.

- (i) Surface treat holes with Chemical Conversion Coating (MIL-C-81706).

WARNING

Epoxy primer coating and Aliphatic Polyurethane Coating are flammable and toxic. They can irritate skin and cause burns. Use only in well ventilated area away from heat and open flame. Wear approved respirator, apron solvent resistant rubber gloves and chemical splash goggles. Thoroughly wash skin area with soap and water. Flush eyes with water for 15 minutes. Get immediate medical attention for eyes.

- (j) Prime hole with epoxy primer coating (MIL-P-23377).
- (k) Attach upper supports (P/N 92276482-1 and P/N 92276482-2) to center post with sixteen rivets (P/N M7885/2-4-03) (Figure 2, view A-A).
- (3) Attach lower support (P/N 92276484-1) to glare shield. Use retained screws (Figure 2, view A-A).
- (4) Temporarily attach adapter plate (P/N 92276483-1) and Trimpack sleeve assembly (P/N90209178-501) to upper supports (P/N 92276482-1 and P/N 92276482-2) (Figure 2, view A-A).
- (5) Transfer aft hole locations of Trimpack sleeve assembly (P/N90209178-501) to lower support (P/N 92276484-1).
- (6) Drill two 0.204 holes in lower support (P/N 92276484-1).
- (7) Clean and deburr holes.

WARNING

Chemical conversion coating is flammable and toxic. It can irritate skin and cause burns. Use only in well ventilated area, away from heat and open flame. Wear gloves, goggles, apron, and respirator. In case of contact, immediately flush skin or eyes with water for at least 15 minutes. Get medical attention for eyes.

CAUTION

Chemical conversion coating is highly corrosive. Do not allow chemical conversion coating or rinse water to run into cracks, crevices, seams, or joints.

- (8) Surface treat hole with Chemical Conversion Coating (MIL-C-81706).

WARNING

Epoxy primer coating and Aliphatic Polyurethane Coating are flammable and toxic. They can irritate skin and cause burns. Use only in well ventilated area away from heat and open flame. Wear approved respirator, apron solvent resistant rubber gloves and chemical splash goggles. Thoroughly wash skin area with soap and water. Flush eyes with water for 15 minutes. Get immediate medical attention for eyes.

- (9) Prime hole with epoxy primer coating (MIL-P-23377).

(10) Attach upper supports (P/N 92276482-1 and P/N 92276482-2) to adapter plate (P/N 92276483-1) and sleeve assembly (90209178-501) with four screws (P/N MS35207-262), eight washers (P/N AN960C10L) and four nuts (P/N MS21042-L3) (Figure 2, view A - A).

(11) Install sleeve assembly (P/N 90209178-501) on lower support (P/N 92276484-1), using two rear screw holes, with two screws (P/N MS35207-262), four washers (P/N AN960C10L) and two nuts (P/N MS21042 L3) (Figure 2, view A-A).

d. Aircraft electrical and antenna wiring Instructions for GPS Trimpack .

- (1) Remove PROX WARN circuit breaker (if installed) in overhead console. Stow wires.
- (2) Install circuit breaker (P/N MS26574-1) in PROX WARN circuit breaker location in overhead console (Figure 3).
- (3) Install GPS placard (P/N 90209223-5) in PROX WARN circuit breaker location on overhead console (Figure 3).
- (4) Starting at Trimpack mount, route power cable (P/N 90209183-504) forward and up left side of windshield center post along existing wire bundles (Figure 4, View B) to GPS circuit breaker.
- (5) Install terminal lug (P/N MS25036-102) on end of power cable (P/N 90209183-504).
- (6) Install power cable (P/N 90209183-504) to load side of GPS circuit breaker (Figure 3, View A).
- (7) Install jumper assembly (P/N 90209223-6) from line side of RDR ALT circuit breaker to line side of GPS circuit breaker (Figure 3, View A).

- (8) Starting at Trimpack mount, route power cable ground wire forward along existing wire bundles behind main instrument panel to local ground (Figure 4, View B).
- (9) Install terminal lug (P/N MS25036-103) on power cable ground wire.
- (11) Connect ground wire to local ground.
- (12) On upper exterior surface of cabin, locate first two rivets inboard of left upper wire strike cutter support.
- (13) Position connector template (P/N 90209223-4) over the two rivets (Figure 5, View C).
- (14) Using template as a guide, drill pilot hole to locate RF bulkhead connector hole. Remove template.
- (15) Ream pilot hole out to 0.500 inches.
- (16) Clean and deburr hole.

WARNING

Chemical conversion coating is flammable and toxic. It can irritate skin and cause burns. Use only in well-ventilated area, away from heat and open flame. Wear gloves, goggles, apron, and respirator. In case of contact, immediately flush skin or eyes with water for at least 15 minutes. Get medical attention for eyes.

CAUTION

Chemical conversion coating is highly corrosive. Do not allow chemical conversion coating or rinse water to run into cracks, crevices, seams, or joints.

- (17) Surface treat hole with Chemical Conversion Coating (MIL-C-81706).

WARNING

Epoxy primer coating and Aliphatic Polyurethane Coating are flammable and toxic. They can irritate skin and cause burns. Use only in well ventilated area away from heat and open flame. Wear approved respirator, apron solvent resistant rubber gloves and chemical splash goggles. Thoroughly wash skin area with soap and water. Flush eyes with water for 15 minutes. Get immediate medical attention for eyes.

- (18) Prime hole with epoxy primer coating (MIL-P-23377).
- (19) From inside cabin, install bulkhead lower antenna cable connector (P/N 90209182-507) with sealant (MIL-S-8802) in 0.500 inch hole.
- (20) Secure cable connector with lockwasher and nut.
- (21) Continue routing antenna cable forward along existing wire bundles, down windshield center post to GPS Trimpack mount.

- (22) Secure antenna cable to existing wire bundles with tywraps (P/N MS3367-1-0).
 - (23) On upper surface of cabin connect upper antenna cable (P/N 90209182-506) to bulkhead connector (Figure 5, View D).
 - (24) Route cable up wire strike cutter to antenna mount (Figure 5, View D).
 - (25) Connect upper antenna cable (P/N 90209182-506) to antenna blank off panel connector (P/N 90209175-501) (Figure 5, View D).
 - (26) Install antenna blank off panel (P/N 90209175-501) on GPS antenna mount (Figure 5, View D).
 - (27) Secure blank off panel to antenna mount with four screws (P/N MS35206-247) and four washers (P/N AN960C8L) (Figure 5, View D).
 - (28) Secure antenna cable to wire strike cutter support with tywraps (P/N MS3367-1-0) (Figure 5, View D).
 - (29) Install clamp (P/N MS21919WDG3) to lower mounting bolt on antenna mount (Figure 5, View D).
 - (30) Secure antenna cable to antenna mount with clamp (P/N MS21919WDG3) (Figure 5, View D).
- e. Final procedures.
- (1) Perform continuity check on coax cable for Trimpack remote antenna.
 - (2) Close access to overhead console circuit breakers and wiring.
 - (3) Install overhead cabin sound proofing blanket.
 - (4) Connect aircraft battery.
 - (5) Apply aircraft power to provide 28 VDC to GPS circuit breaker.
 - (6) Verify pin B of GPS five pin audio connector is common with airframe ground.
 - (7) Verify that pin D has 28VDC (Figure 7).

10. KIT B INSTALLATION PROCEDURES.

- a. Remove GPS antenna Blank off panel (if installed) from GPS antenna mount (Figure 5, view D).
- b. Connect GPS upper antenna cable to connector on GPS antenna (P/N 12038-00 or 1624840).
- c. Install GPS antenna on mount (Figure 6).
- d. Secure with four screws (P/N MS35206247) and four washer (P/N AN960C8L) (Figure 6).

NOTE

Only Trimble Trimpack GPS receiver P/N's 16768-10 and 1676820 are allowed for this installation. These receivers have software that compensates for the effects of rotor modulation and have green lighting. All other Trimble Trimpack receivers cannot be used. The P/N is located on a nameplate located between the receiver and battery pack. The battery pack must be moved to see the name plate. An ANVIS (Aviator's Night Vision Imaging System) filter modification kit (NSN 5895-01-340-5502) has been developed and when used with either GPS receiver will provide an ANVIS acceptable display. Installation instructions for this ANVIS filter modification are contained in document, ILS 91-ANV0002, dated March 1991 provided with the ANVIS kit.

- e. Remove caps from GPS Trimpack receiver power connector and external antenna cable connector. Tape caps to side of receiver with tape (PPP-T-42) to prevent chafing
- f. Install GPS Trimpack receiver in mount and secure with clamp assemblies (Figure 6).
- g. Connect power and antenna cables to receiver (Figure 6).

11. GPS CHECKOUT PROCEDURES.

- a. Move aircraft to ramp area with good satellite visibility.
- b. Apply aircraft power.
- c. Apply power to Trimpack. Check that it acquires satellites visible at time of test. If GPS powers up and acquires satellites check is complete.

NOTE

If Trimpack receiver is removed from aircraft and operated on internal batteries external power connector cap must be installed.

- d. If GPS does not power up and aircraft power is present:
 - (1) Check GPS circuit breaker in.
 - (2) Check power connections to Trimpack receiver.
 - (3) Check power cable routing and connection to circuit breaker.
- e. If GPS does not acquire satellites:
 - (1) Check antenna cable connection to Trimpack receiver.
 - (2) Check antenna cable connection to bulkhead connector.
 - (3) Check antenna cable connection to GPS antenna.
 - (4) Recheck antenna installation.
- f. Aircraft power off.

12. KIT B REMOVAL PROCEDURE.

- a. Remove GPS antenna from mount.
- b. Disconnect GPS antenna cable.
- c. Connect GPS antenna cable to Blank off panel (P/N 90209175-501).
- d. Install antenna Blank off panel (P/N 90209175-501) on GPS antenna mount with four screws (P/N MS35206-247) and washers (P/N AN960C8L) (Figure 5).
- e. Remove Trimpack receiver from mount.
- f. Disconnect antenna and power cables.
- g. Install caps on Trimpack connectors.

13. KIT A REMOVAL PROCEDURE.

- a. Prepare aircraft for safe ground maintenance (TM 55-1520-228-23)
- b. Lower overhead console circuit breaker panel for access to power distribution wiring.
- c. Remove upper cabin sound proofing blanket as required to gain access to wire bundles and GPS antenna cable routing.
- d. Remove antenna blank off panel from GPS antenna mount.
- e. Disconnect GPS antenna from antenna blank off connector.
- f. Remove Trimpack remote antenna mounts (P/N 90209223-1 and P/N 90209223-2) from upper wire strike cutter.
- g. Remove GPS Trimpack lower support (P/N 92276484-1) (figure 2).
- h. Remove GPS Trimpack sleeve assembly (P/N 90209178-501) (figure 2).
- i. Remove GPS Trimpack upper supports (LS and RS) (P/N 92276482-1 and P/N 92276482-2) (figure 2).
- j. Remove jumper wire from line side of RDR ALT circuit breaker and line side of GPS circuit breaker (Figure 3, View A).
- k. Remove GPS power wire from GPS circuit breaker (Figure 3, view A).
- l. Remove GPS circuit breaker (P/N MS26574-1) from overhead console (Figure 3).
- m. Remove GPS circuit breaker placard from overhead console (Figure 3).
- n. Disconnect GPS power cable ground terminal from ground behind main Instrument panel.
- o. Remove GPS power cable.

- p. Remove upper antenna cable (P/N 90209182-506) from bulkhead connector (P/N 90209182-507) on exterior surface of cabin.
- q. Remove bulkhead connector end of lower antenna cable (P/N 90209182-507) from upper cabin structure.
- r. Remove upper antenna cable.
- s. Remove lower antenna cable.
- t. Patch/repair antenna cable hole in upper cabin structure (TM 1-1500-204-23).
- u. Close access to overhead console circuit breakers and wiring.
- v. Install overhead cabin sound proofing blanket.

14. WEIGHT AND BALANCE DATA. Make entries on DD Form 365-1 (Chart A) and DD Form 365-3 (Chart C) in accordance with TM 55-1520-228-23 and TM 55-1500-342-23, as indicated below:

- a. Chart A. Make the following entry (OH-58C Flat Glass):

| ITEM NO. | DESCRIPTION | WEIGHT (lbs.) | ARM (in.) | Moment/100 (in lbs) |
|----------|------------------------|----------------|------------|---------------------|
| A- | GPS Antenna | 0.3 | 35.0 | 0.10 |
| A- | GPS Receiver, Trimpack | 4.2 | 42.0 | 1.76 |

- b. Chart C. Make the following entry (OH-58C Flat Glass):

| ITEM NO. | | DESCRIPTION | ADDED (+) | | | REMOVED (-) | | |
|----------|-----|--|-----------|------|---------|-------------|-----|---------|
| IN | OUT | | WT. | ARM | MOM/100 | WT. | ARM | MOM/100 |
| A- | | TB 1-1520-228-20-81 Provisions for GPS Receiver | 2.8 | 38.3 | 1.07 | | | |

15. RECORDING AND REPORTING REQUIREMENTS.

Records and Reports.

The following forms are applicable and are to be completed in accordance with DA PAM 738751, TAMMS-A.

- (1) DA Form 2408-5, Aircraft Equipment Modification Record.
- (2) DA Form 2408-13, Aircraft Status Information Record.
- (3) DA Form 240813-1, Aircraft Inspection and Maintenance Record.
- (4) DA Form 2408-13-2, Related Maintenance Action Record.
- (5) DA Form 2408-13-3, Technical Inspector Worksheet.
- (6) DA Form 2408-15, Historical Record for Aircraft.

16. Points of Contact for this Technical Bulletin.

(a) Technical is Mr. Peter Nyquist, DSN 995-3542 or commercial (908) 544-3542 or Mr. Jeff Dworkin, DSN 624-2119 or Commercial (908) 323-2119.

(b) Logistical is Ms. Vellna Mentel, SAVAA-ILS, DSN 995-4175 or Commercial (908) 5444175 or Ms. Evelyn Thomas DSN 693-5568 or Commercial (314) 263-5568.

(c) Forms and Records is Mrs. Ann Waldeck, AMSAT-I-MDM, DSN 693-1821 or commercial (314) 263-1821.

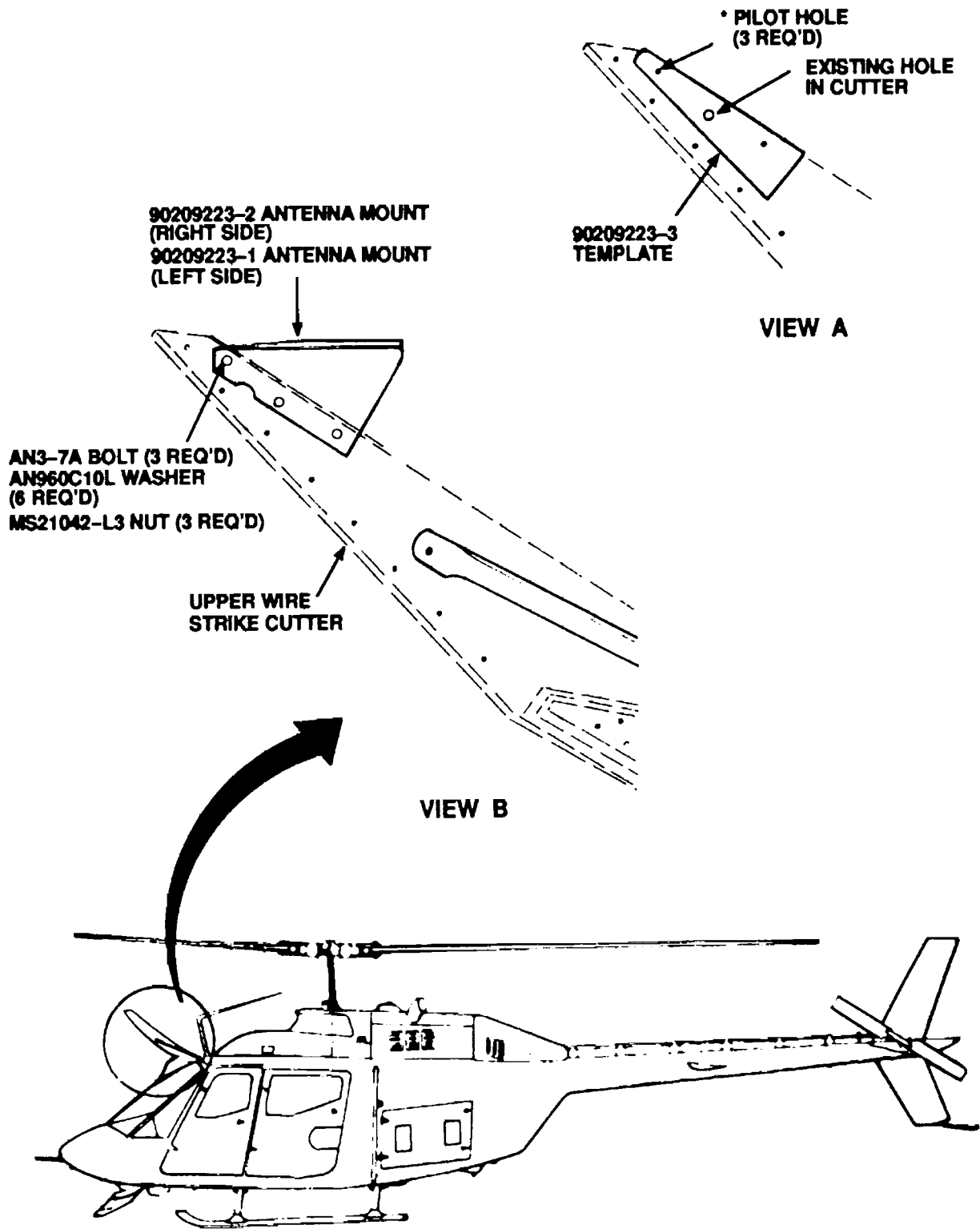

Figure 1. GPS Antenna Mount Installation.

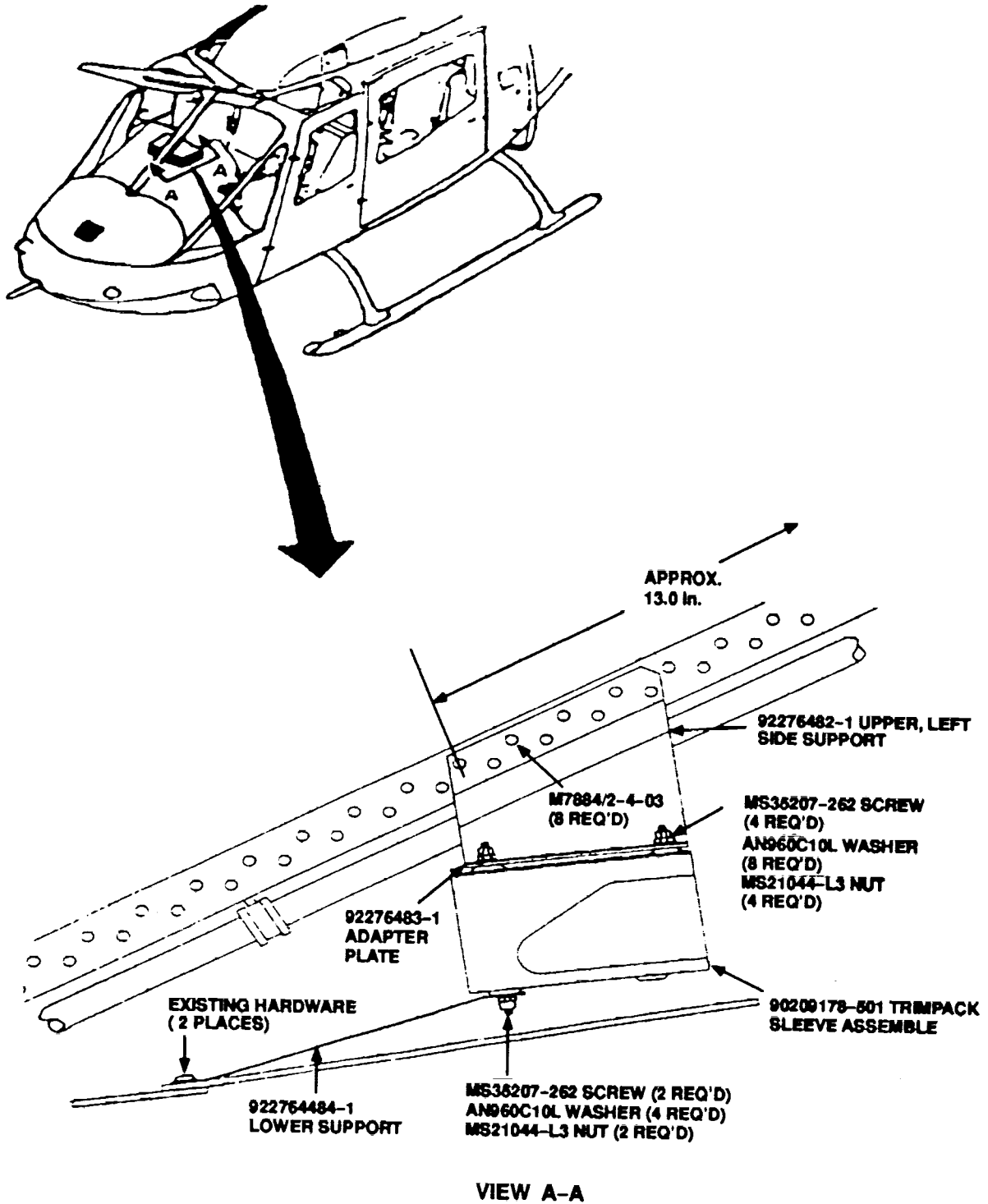

Figure 2. GPS Trimpack Receiver Mount Installation.

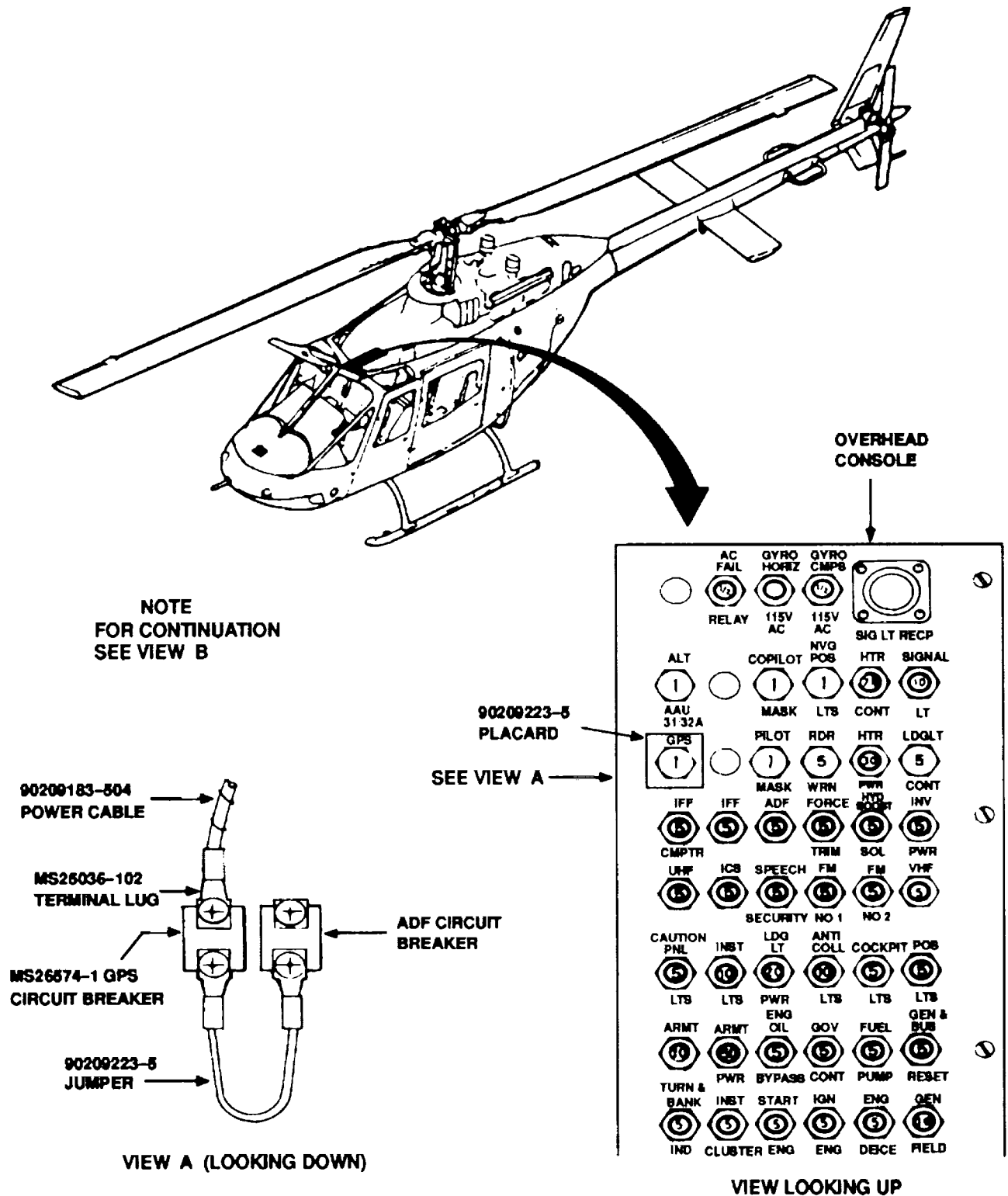

Figure 3. GPS Power Cable and Circuit Breaker Installation.

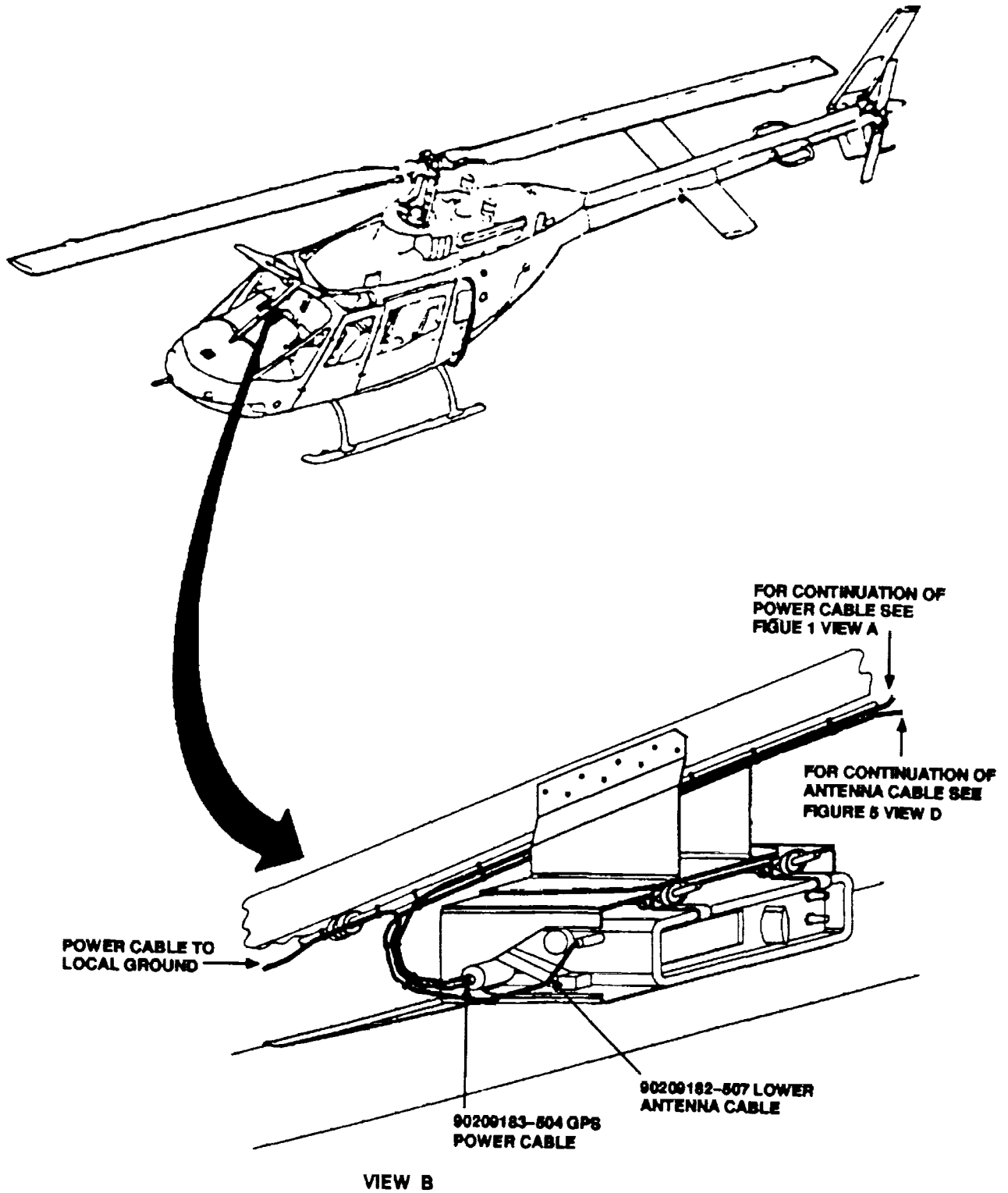

Figure 4. GPS Power and Antenna Cable Installation.

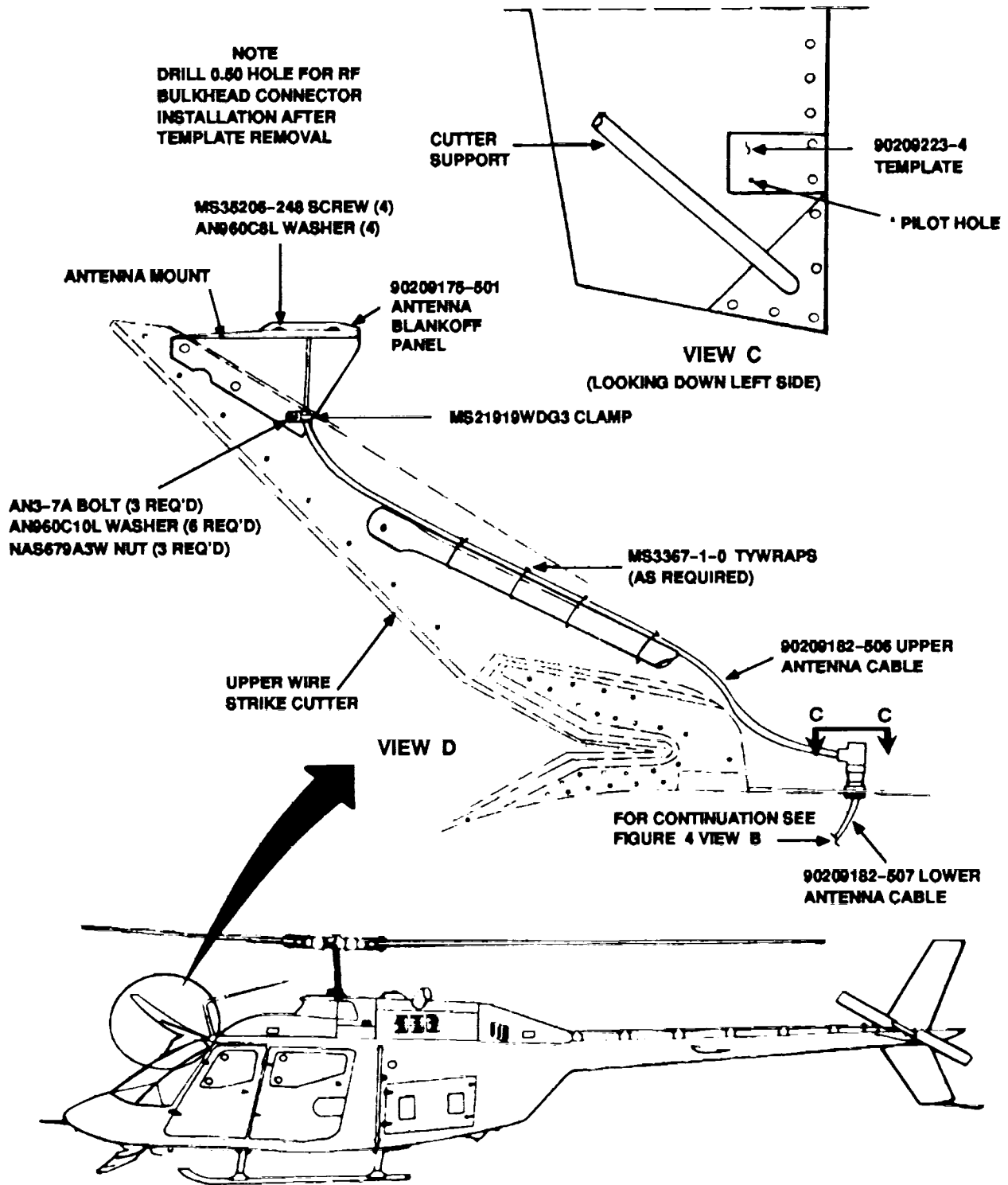

Figure 5. GPS Antenna Cable Installation.

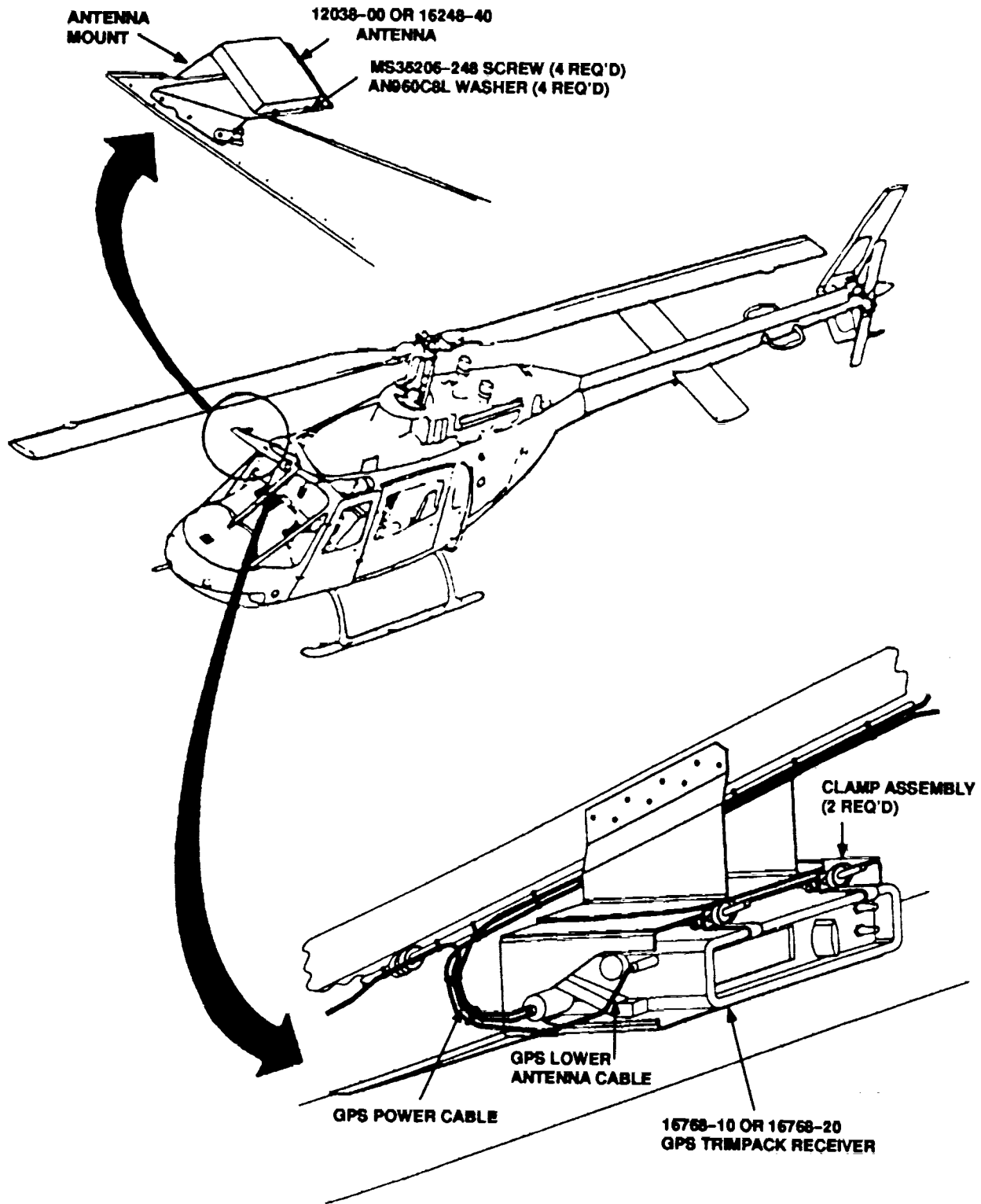

Figure 6. GPS Antenna and Trimpack Receiver Installation.

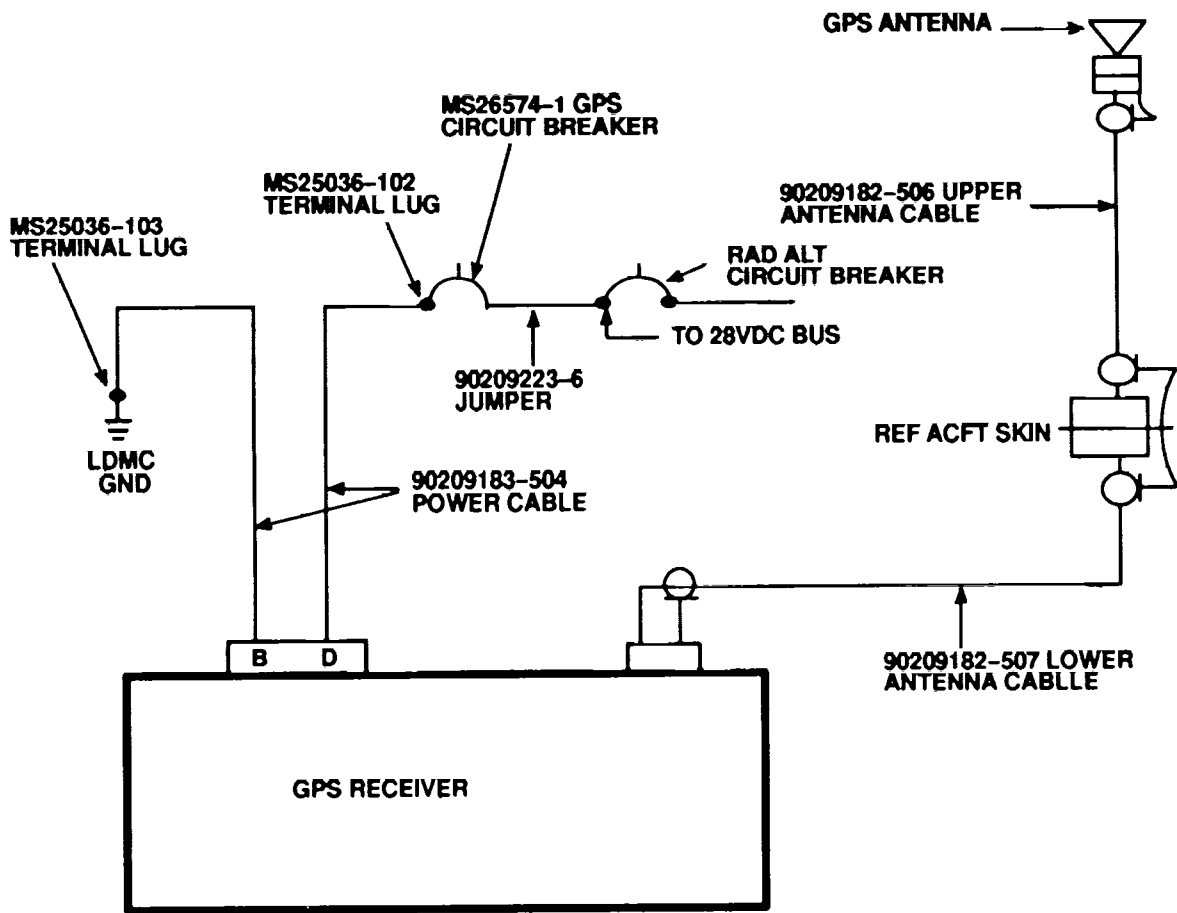

Figure 7. GPS Wiring Diagram.

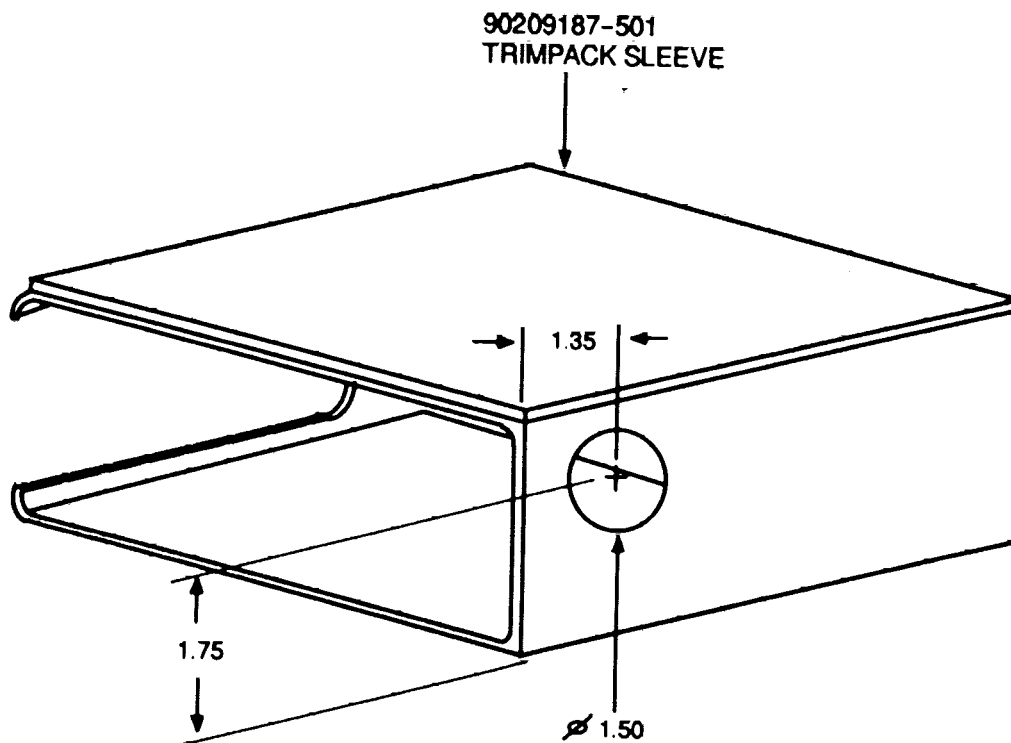



Figure 8. Trimpack Sleeve Modification.

By Order of the Secretary of the Army:

GORDON R. SULLIVAN
General, United States Army
Chief of Staff

Official:



JOEL B. HUDSON
Acting Administrative Assistant to the
Secretary of the Army

00445

DISTRIBUTION:

To be distributed in accordance with DA Form 12-31-E, block no. 3494, requirements for
TB 1-1520-228-20-81.

RECOMMENDED CHANGES TO EQUIPMENT TECHNICAL PUBLICATIONS

| | | | | |
|---|------------|--|-----------|---|
|  <p style="text-align: center;"><i>THEN...JOT DOWN THE DOPE ABOUT IT ON THIS FORM. CAREFULLY TEAR IT OUT, FOLD IT AND DROP IT IN THE MAIL.</i></p> | | SOMETHING WRONG WITH PUBLICATION | | |
| | | FROM: (PRINT YOUR UNIT'S COMPLETE ADDRESS) | | |
| PUBLICATION NUMBER | | DATE SENT | | |
| PUBLICATION DATE | | PUBLICATION TITLE | | |
| BE EXACT PIN-POINT WHERE IT IS | | | | |
| PAGE NO. | PARA-GRAPH | FIGURE NO. | TABLE NO. | <p style="text-align: center; font-weight: bold;">IN THIS SPACE, TELL WHAT IS WRONG AND WHAT SHOULD BE DONE ABOUT IT.</p> |
| | | | | |
| PRINTED NAME, GRADE OR TITLE AND TELEPHONE NUMBER | | | SIGN HERE | |

